

REACT

QUALITY FIRST

T400 WHEEL LOADER - 150HP



SPEC SHEET

SPECIAL FEATURES

- 4 Ton Capacity
 - 150 HP Cummins 6BTA5.9-C150-11
 - Genuine Cummins 2000 hr/2yr Warranty
 - New Engine Inspection By Cummins Before Delivery
 - Large Aluminium Radiator
 - Long Life (Anti Corrosion) Coolant Concentrate Used
 - ROPS / FOPS
 - Rego / UHF – Road Pack Available
 - ZF YD13 Powershift Transmission
 - 4 Fwd / 3 Rev Gears with Safety Lock Out
 - 40 km/h Road Speed
 - Gear Kick Down Function
 - 2.5m³ General Purpose Bucket
 - HD GP Forks
 - HD Hay Forks
 - Rear Ripper Options
 - 12 Stud Axles
 - Steering Priority Valve
 - Hydraulic Pilot Control
 - Auto Forward Reverse
 - Hydraulic Quick Release Hitch with Safety Lock Out
 - 3100 mm Dumping Height
 - Float Function
 - Auto Level
 - 3rd Function Hydraulics
 - Spiral Wrap (Hyd Hose Protection)
 - Auto Greasing
 - Luxurious Extra Large Cab (Wraparound Windscreen)
 - Reverse Camera / Reverse Alarm
 - Fm Radio, Fire Extinguisher, Drink Holder & Glass Breaker
 - Battery Isolation Switch
 - Adjustable Steering Column
 - Sound Proofing, Cab Fan & Sun Visor
 - Electric Park Brake
 - UV Protected Windows
 - Australian Standards Air Conditioning
 - LED Long Bars Front & Rear
 - LED Lights, Blinkers, Hazards & Mirrors
 - High Lift Engine Bonnet
 - Brilliant Access to Filters, AC & Engine Components
 - Rear Access Door to Radiator
- * Finance Available Through Finlease
* Numerous Attachments
* Extensive Pre Delivery



IAN EVANS
0427 180 673
IAN@TOUGHINDUSTRIAL.COM.AU

SHANE BLUMSON
0436 521 151
SHANE@TOUGHINDUSTRIAL.COM.AU

LOCATION: 15 CARDIFF CRT. CAVAN. ADELAIDE - SOUTH AUSTRALIA

REACT

QUALITY FIRST



T400 WHEEL LOADER - 150HP

SPEC SHEET

TECHNICAL SPECIFICATIONS - 4 TON CAPACITY

Performance

Rated Load	4,000 kg
Overall Weight	12,000 kg
Bucket Capacity	2.5 m ³
Underbelly Clearance	450 mm
Max. Dump Height	3,100 mm
Max. Dump Reach	1,100 mm
Overall Dimension	Length 7,250 mm Width 2,500 mm Height 3,300 mm

Min. Turning Radius	5160 mm
---------------------	---------

Engine

Model	Cummins 6BTA5.9-C150
Type	Turbocharged / Water Cooled
Rated RPM	2,200 rpm
Rated Power	150 hp / 112 kw
Max. Torque	670 nm

Service Refill Capacities

Fuel	140 ltr
Hydraulic Oil	80 ltr
Engine Oil	15 ltr
Transmission	39 ltr
Axles x 2	16 ltr

Transmission

Type	ZF YD13 Powershift Transmission
Gears	4 Forward, 3 Reverse
Working Pressure	1.6 mpa
Max. Speed	38 km/h

Drive Axle

Main Reducing Spiral Decelerating Mode	Planetary reduction
Wheel Base	2,845 mm
Inner Wheel Tread	1,250 mm
Ground Clearance	500mm

Hydraulic System

System Working Pressure	18.5 mpa
Boom Lifting Time (max load)	5.5 Sec
Lowering Time (empty)	3.5 Sec
Dumping Time (empty)	1.5 Sec
Auto Bucket Level	Yes
3rd Function Oil Flow	180 - 200 lpm

Tyres

Type	20.5-25 20 pr
Front Tyre Pressure	50 psi
Rear Tyre Pressure	42 psi

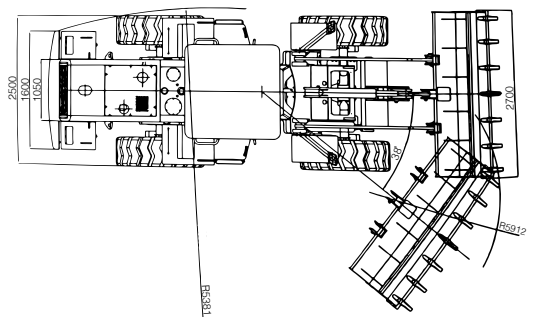
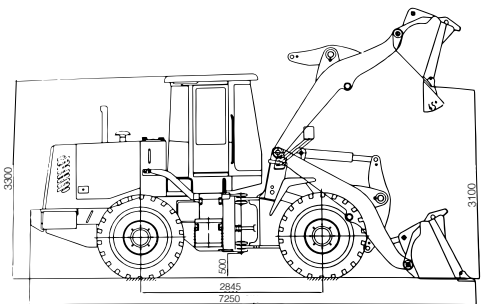

Prices exclude GST

WWW.REACTINTERNATIONAL.COM.AU